

VERSION 1
WERSJA 1

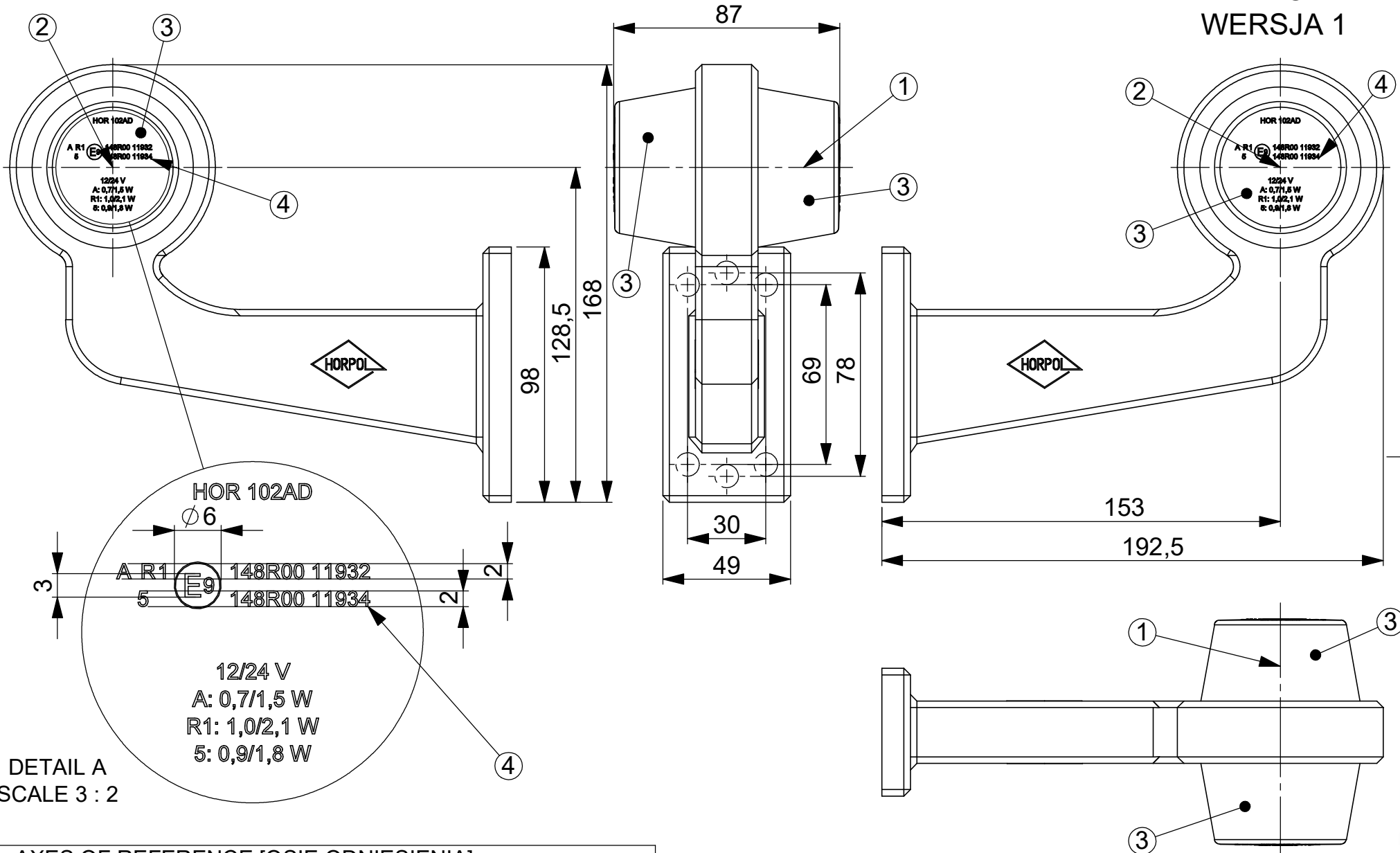

- 1 - AXES OF REFERENCE [OSIE ODNIESIENIA]
- 2 - CENTRES OF REFERENCE [ŚRODKI ODNIESIENIA]
- 3 - SIDE DIRECTION INDICATOR [KIERUNKOWSKAZ BOCZNY]
- 4 - APPROVAL NUMBER [NUMER HOMOLOGACJI]

SIDE DIRECTION INDICATOR CAT. 5 TYPE HOR 102AD/5
KIERUNKOWSKAZ BOCZNY KAT. 5 TYPU HOR 102AD/5

trade name: **HORPOL**
manufacturer: **HORPOL J.I.A.T. Horeczy Spółka Komandytowa**

Drawn by: Marcin Gorzqch Scale 1:2 Date: 18.12.2023 Sheet: 1/7

IDIADA PC23080162

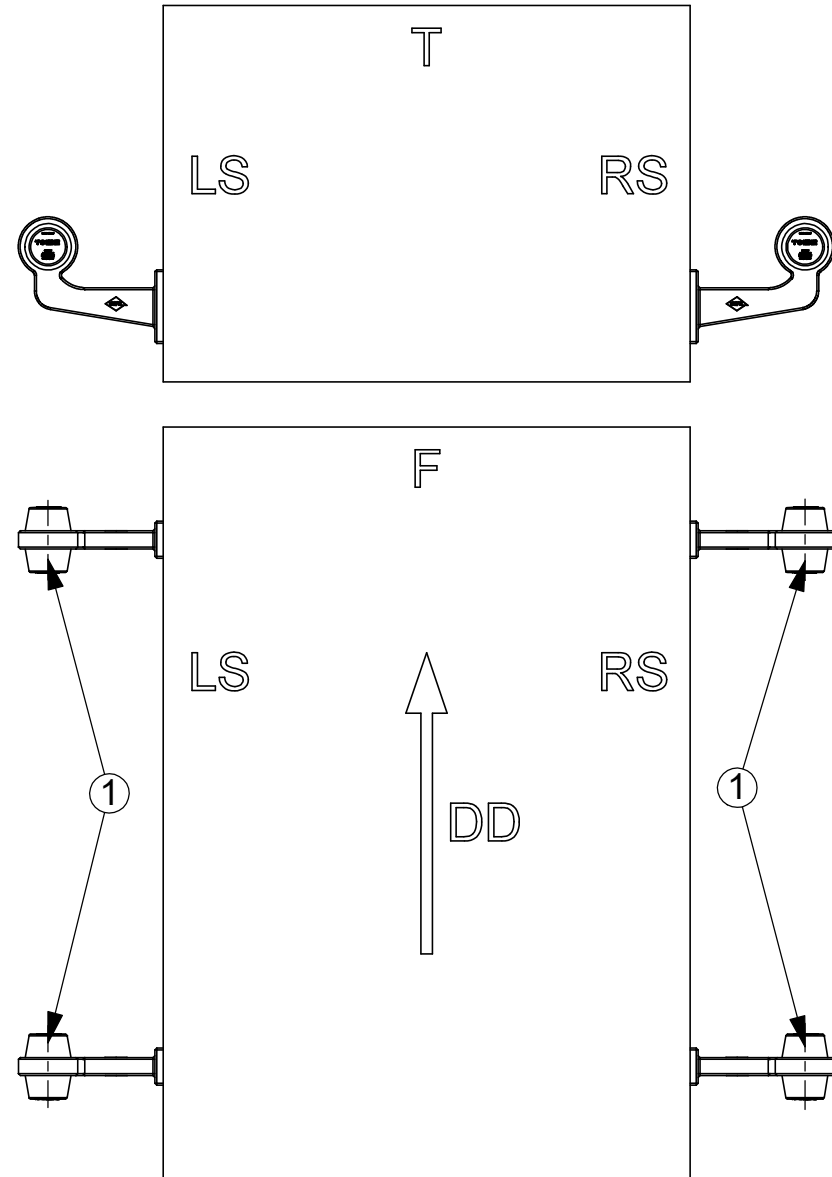
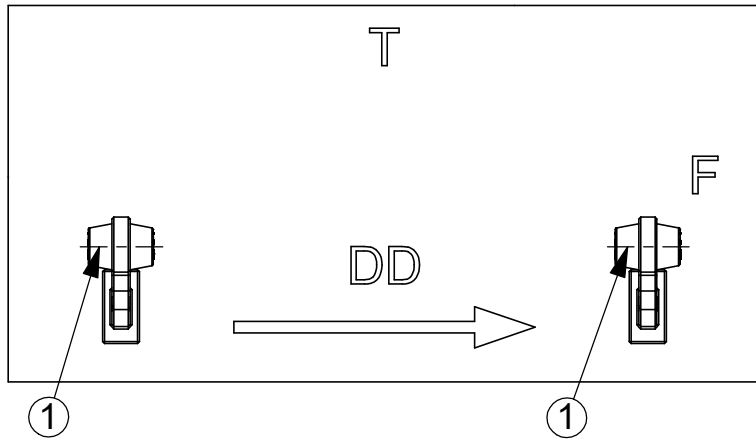

VERSION 1
WERSJA 1

1- AXIS OF REFERENCE [OŚ ODNIESIENIA]
 LS - LEFT SIDE OF THE VEHICLE [LEWA STRONA POJAZDU]
 RS - RIGHT SIDE OF THE VEHICLE [PRAWA STRONA POJAZDU]
 F - FRONT OF THE VEHICLE [PRZÓD POJAZDU]
 T - TOP OF THE VEHICLE [GÓRA POJAZDU]
 DD - DRIVING DIRECTION [KIERUNEK JAZDY]

SIDE DIRECTION INDICATOR CAT. 5 TYPE HOR 102AD/5 KIERUNKOWSKAZ BOCZNY KAT. 5 TYPU HOR 102AD/5		
trade name: HORPOL manufacturer: HORPOL J.I.A.T. Horeczy Spółka Komandytowa		
Drawn by: Marcin Gorzqch	Scale 1:20	Date: 18.12.2023
		Sheet: 4/7

IDIADA PC23080162